



DYCON
power solutions

Dycon D1632

90-264VAC 12V 2A Power Supply

**Technical Description,
Installation and Operating Manual**

DYCON POWER SOLUTIONS LTD
+44 (0)1443 471900
Unit A - Cwm Cynon Business Park - Mountain Ash –
CF45 4ER - UK

www.dyconpower.com - sales@dyconpower.com

Contents

DYCON POWER SOLUTIONS LTD	1
1. General	3
1.1 Product Range.....	3
1.2 Features.....	3
2. Electrical and Operational Specifications	3
3. Compliance	4
4. Power Supply Physical Dimensions and Features	5
4.1 Printed Circuit Board	5
5. Installation and Operation	5
5.1 Mounting	5
5.2 AC Power Connection and Wiring.....	5
5.3 Jumper Link	6
5.4 LED Display	6
5.5 Dynamic Load Sharing	6
5.6 12VDC Output	7
5.7 SW Input.....	7
5.8 Fault detection and Outputs	7
5.8.1 AC Fault and Bat Fault.....	8
5.9 Batteries.....	8
5.9.1 Battery Protection.....	8
5.9.2 General Maintenance	9
6.0 Integral Data Interface/Port.....	9
7.0 EN50131 Harmonised Technical Specification	9

1. General

1.1 Product Range

The D1632 series of product consists of the following products:

- D1632-P: PCB only, unboxed (size: H 100mm x W 130mm x D 42mm)
- D1632-B: 'B' box (size: H 260mm x W 320mm x D 90mm)
- D1632-XLB: 'XLB' box (size: H 295mm x W 415mm x D 90mm)
- D1632-XLBD: 'XLBD' extra-deep box (size: H 295mm x W 415mm x D 165mm)
- D1632-XB: 'XB' clam-shell lid box (size: H 295mm x W 415mm x D 90mm)
- D1632-C: 'C' box size (size: H 345 mm x W 430mm x D 90mm)
- D1632-E: 'E' box (size: H 405mm x W 500mm x D 90mm)
- D1632-G: 'G' box (size: H 690mm x W 455mm x D 165mm)
- D1632-W: 'W' IP65 box (size: H 245mm x D 195mm x D 90mm)

1.2 Features

The D1632 power supply can be used for intruder alarm applications complying with EN 50131, Grade 1, 2 and 3, PS Type A and EN 50136 series of standards (maximum output of 2A to comply).

The power supply provides a nominal 12V output at a maximum of 2A, rated at 2A operational current when fitted with a 24AH lead acid battery to provide a 2A standby current. The power supply has the following features:

- Microprocessor controlled operation and protection
- On-demand battery charging and load output current sharing (Dynamic Load Sharing: DLS)
- Non-user serviceable output fuse, protected by electronic E-fuse and hick up mode
- Automatic output reconnection after short circuit fault
- Switched output with programmable (jumper selectable) control input Normally open or Normally closed.
- Open collector fault outputs for status communication: AC power Fail, Battery Fault
- Battery condition impedance testing
- Deep discharge battery protection
- Battery reverse connection protection
- Battery charging safe area power limiting
- On-board four LED status display
- Two-stage over and under voltage output protection

2. Electrical and Operational Specifications

AC Input Voltage	90-264VAC, 45-65Hz.
Maximum Input Continuous Current	300mA
Recommended Switched Spur Input Fuse	250V, T1A, 1.5KA break
Voltage Output AC Present	Minimum 13.6VDC, Maximum 13.9VDC No Load. Minimum 13.4VDC at 3A load
Voltage Output Standby	Minimum 10.5VDC, 12VDC Nominal No Load Minimum 9.5VDC at 3A total load, including battery charging
Total Continuous Output Current With 24AH Battery	1.5A
Peak output current	2.5A
Battery Type	Sealed Lead Acid Gel 12V nominal. NOTE: For EN50131 Grade 3 Compliance, please check relevant standard
24AH Battery Recharge Time	24 hours for 80% charge capacity
Battery Charging Current	On demand, load-sharing, maximum 2.5A

Battery Terminal Low Voltage APS Fault detection thresholds	<11V \pm 2%, low voltage restore, >11.5V \pm 2%.
Battery Circuit Impedance Threshold	>0.18 Ohm \pm 5%, at a nominal test current of 5A.
Battery Terminal Deep Discharge Disconnection Threshold	10.5V \pm 2%.
Overvoltage Detection Shutdown Threshold	>15V \pm 2%.
On-Board AC Power Input Fuses	20mm x 5mm, 250V, T1A, 1.5KA break ceramic
Battery Fuse	PTC, self-resetting, non-replaceable.
Opto-Relays for faults with EPS (AC power), APS (Battery) and PSU (Power Supply unit)	Normally closed, 100mA at 60V. On-Resistance 16 ohms maximum, 1500VRMS Isolation voltage
Outputs for Battery fault, Generic fault and AC fault	Open collectors, Normally Off, 100mA at 50V
Switching input	Logic "1" >4V, logic "0" <1V, 30V tolerant, weak 100K pull-up/pull-down
PSU Standby Current	30mA maximum
Maximum Ripple Voltage	0.7V peak to peak.
Battery current drawn by power supply without mains	Maximum 90mA, typical 30mA (Depending On PSU Status)
Operating Temperature and Humidity Range	-10°C to +40°C, 75% maximum humidity, non-condensing

3. Compliance

The power supplies comply with the following European Directives:

Low Voltage: 2006/95/EC

EMC: 2014/30/EU

WEEE: 2012/19/EU

RoHs: 2011/65/EU

IEC 61140:2016: Protection against electric shock – Common aspects for installation and equipment: Class 1

BS EN 50131-6:2008+A1:2014: Alarm systems. Intrusion and hold-up systems. Power supplies

4. Power Supply Physical Dimensions and Features

4.1 Printed Circuit Board

The PCB is 42mm deep including plastic safety cage and the layout is shown below:

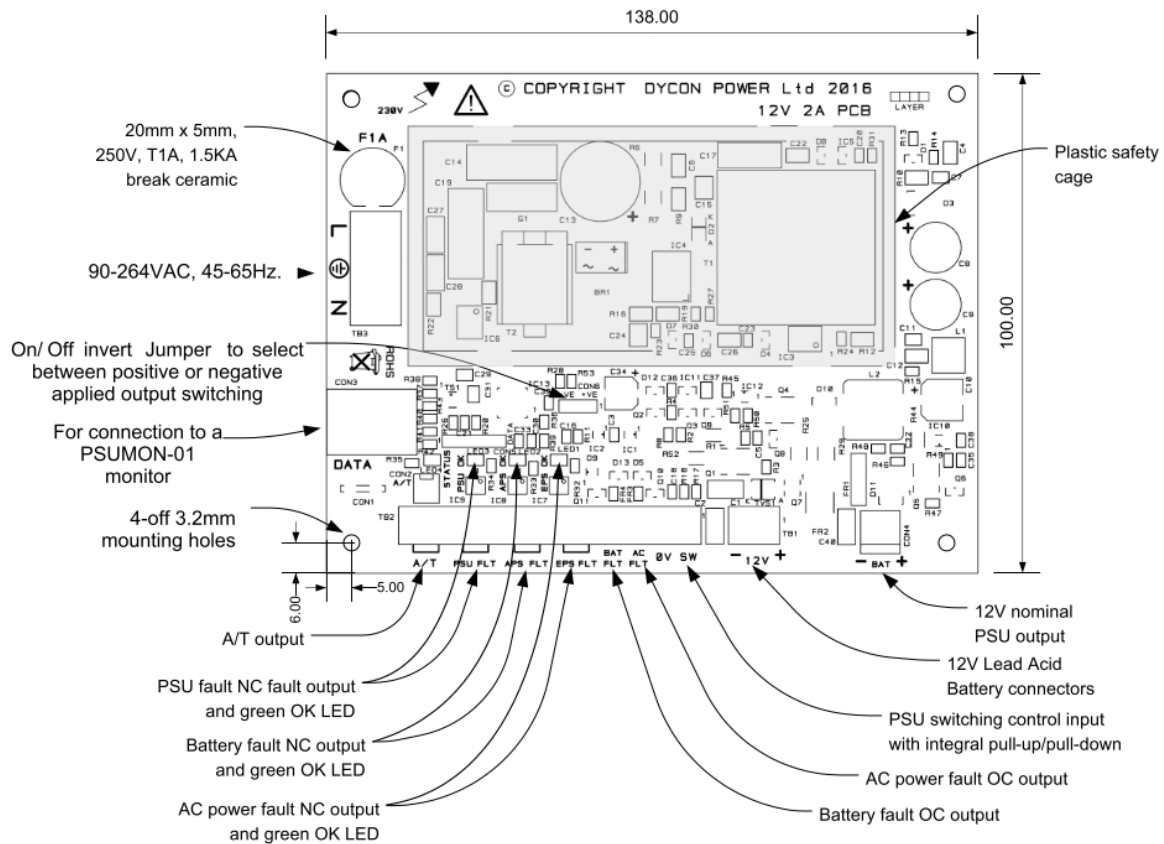

5. Installation and Operation

Warning: Isolate the AC power supply before working on the power supply. Only suitably qualified personnel should install these power supplies and wiring should comply with the latest edition of IEE Wiring Regulations (BS 7671) or local national electrical standards.

5.1 Mounting

The power supplies are designed for indoor use, within the specified operational temperature and humidity limits.

The metal enclosures should be mounted on a solid, flat and dry surface using the three mounting points provided. The screws should have a minimum shank diameter of 5mm (No 11 gauge) and use suitable wall plugs where needed. Separate holes should be used for AC power entry and low voltage wiring and the wiring kept apart.

The power supplies should not be mounted near sources of heat or moisture and should be accessible for ease of fitting heavy batteries.

The keyhole slot at the top of the enclosure may be used as a first fix to hang the unit where the bottom two holes can be marked off when level and then removed for drilling. Using the enclosure directly as a drilling template should not be done as it risks dust damage.

5.2 AC Power Connection and Wiring

AC power with a protective earth for Class 1 equipment is to be used with an isolating switched spur using the recommended fuse ratings or a fuse rating of not greater than 5A. The fused switched spur should be fitted as close to the power supply as practicable to allow isolation when the unit is serviced. AC power cable with conductors of a cross sectional area greater than 0.75mm should be used.

The AC power cables shall be segregated from the low voltage control wiring and outputs to load. 20mm diameter knockouts on the four sides of the box are provided for cable glands.

5.3 Jumper Link

A jumper link is provided for selecting the PSU switching input polarity. There are three jumper pins and the jumper can be placed in either a right-hand (+VE), or left-hand (-VE) position:

JUMPER POSITION	OPERATION
No Jumper fitted	Switched input will default into a positive 100K pull-up to 5V reference and an applied negative (0V) will switch off the PSU output.
+VE (right-hand) position	Switched input is selected for a positive 100K pull-up to 5V reference and an applied negative (0V) will switch off the PSU output.
-VE (left-hand) position	Switched input is selected for a negative 100K pull-down to 0V reference and an applied positive will switch off the PSU output.

NOTES

1. It is recommended to fit the jumper to select the desired switching input operation as the link provides stable 0V and 5V reference levels to the input.
2. The output will be switched on by default if the jumper link is left off when the switched input is left unconnected.

5.4 LED Display

Four board mounted LEDs are used to provide output switched status and fault display.

STATUS: The green LED indicates the output ON/Off status controlled by the SW input.

PSU FLT: The green LED is lit when no power supply related faults are detected (OK).

APS FLT: The green LED is lit when no battery related faults are detected (OK).

EPS OK: The green LED is lit when AC power is available (OK).

5.5 Dynamic Load Sharing

The power supply features DLS that shares the PSU output current between the output and battery charging current where the output has priority and any excess current capacity is diverted to charging the battery.

For example, if there is a steady 1A load applied to the output, then 1A would be available to charge the battery.

This load sharing is real-time and the charging current is continuously modulated by the output load. Should the power supply output be loaded with its maximum of 2A, the battery will be charged with a 300mA reserve capacity.

The on-demand load sharing capability gives the power supply range exceptional flexibility. This allows rapid large capacity battery charging with either extended standby hold-up duration at light loads, or short high current peak loads where spare output capacity is diverted for fast battery charging while the load is switched off or in standby mode.

5.6 12VDC Output

Due to high instantaneous current that can flow under fault conditions and voltage drops over long cable runs, the DC output wire is recommended to be 1mm cross sectional area or greater.

The output is protected against short circuits. The output can be switched using the SW output control input. The output is fully protected against switching transients and are suitable for switching highly inductive loads such as door strikes and magnets. The output current must not exceed a peak output current rating of 2.6A.

The power supply features DLS (see above) and therefore various popular battery capacities with load output ratings can be catered for that would comply with the 12-hour battery recharge period required by EN 50131 Grade 3 standards.

5.7 SW Input

This input can be used to switch on and off the output. The polarity of this input is selected by the -VE and +VE jumper. For logical operation see specification and section 5.3.

The wiring to these inputs shall not be more than 3 meters in length.

The inputs have a 100K pull-up resistor and are 30V tolerant. They are designed to be easily driven by a 5V logic output, relay contacts or open collector transistors, see drive examples below:

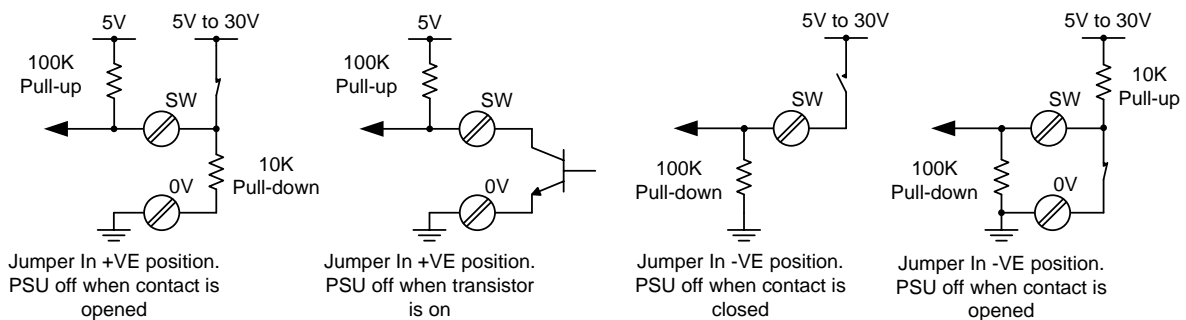

5.8 Fault detection and Outputs

Three normally closed relay outputs in no-fault conditions are provided for fault signalling and will open when a fault is detected. If a generic PSU fault is required, then the outputs can be connected in series as shown below:

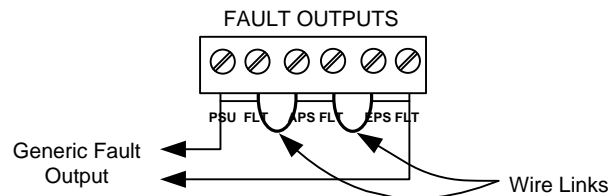

The table below shows the relation between fault and outputs.

FAULT	OUTPUT	DESCRIPTION
AC power missing	EPS FLT	A fault will be generated if the incoming External Power Source fails.
PSU low voltage	PSU FLT	If the internal PSU power rail voltage is too low due to overloading, over-temperature or a component failure, a fault will be generated.
PSU Overvoltage	PSU FLT	If the power supply voltage becomes too high, the output and battery charging will be switched off and a latched fault generated. Two-stage over-voltage protection is used, the low voltage DC section is software protected, the high-voltage AC section is hardware protected. The PSU should be switched off for 15 minutes to attempt to reset the fault.

FAULT	OUTPUT	DESCRIPTION
OP fault	PSU FLT	When overloaded (shorted) The outputs will automatically retry to restore power every 5 seconds until the overload (short) is removed.
PSU battery charging failure	PSU FLT	If the PSU cannot charge the battery due to an internal failure, a fault will be generated.
Battery connection fault	APS FLT	If any of the battery connectors are disconnected a battery fault will be generated.
Battery high resistance fault	APS FLT	The battery together with battery connections are tested every hour and if the resistance is too high, a fault is generated. The testing starts 5 minutes after the PSU is powered up.
Battery Low Fault	APS FLT	If the battery is left to discharge to low when the PSU is in standby mode, a fault will be generated.
Battery charging overload	APS FLT	If the battery overloads the PSU charging circuit due to a failure, a fault will be generated

5.8.1 AC Fault and Bat Fault

Two, separate, normally-on, open-collector outputs are provided for signalling faults to a local SPT (Supervised Premises Transceiver, or communicator) for remote signalling. They will be switched off under the following conditions:

Battery fault: When any battery fault as listed in section 5.7 is detected.

AC fault: When the incoming External Power Source is continuously removed for more than 10 seconds, restored when AC is present for more than 1 second.

5.9 Batteries

Warning: There is a risk of fire and explosion if the wrong battery or battery connection cable is fitted. Care should be taken with polarity when connecting the batteries (Europe) and, in accordance with other regulations in countries outside Europe.

The size of the batteries is dependent on the size of the box, the load current and the amount of standby time required. The battery cables are to be segregated from the incoming AC power supply wiring.

To achieve the requisite 12 hour standby duration for the full 2A output, you will require a minimum of a 24Ah battery or permutations of 7/8 Ah or 17 to achieve the same figure. This may require an additional battery box if you are using the A or B-boxes.

5.9.1 Battery Protection

The batteries are reverse connection protected and the battery charging output is protected from short circuits.

The battery output is overload protected by a resettable fuse in addition to an electronic output fuse. If this fuse is tripped, then the battery should be disconnected for 5 minutes to allow the fuse to reset.

When in standby mode the battery is switched off when the battery terminal voltage reaches 10.5V to prevent battery deep discharge damage. This fault is normally reset by restoring the AC power supply.

5.9.2 General Maintenance

Warning: Isolate the AC power supply before removing the power supply lid. Do not touch components or heat sinks as there is risk of electric shock or burn hazard.

The power supply should be regularly inspected by qualified personnel and the following checked:

1. No faults are displayed.
2. Battery terminals checked for corrosion and the terminals are secure.
3. The battery voltage must be checked and the battery manufacturer's specifications should be consulted when making battery voltage measurements.
4. Battery replacement is recommended after a 5-year service life.
5. Check there are no signs of water or moisture ingress and there is no mechanical damage to the enclosure.
6. Check for signs of overheating on the power supply board and battery cases.
7. Check the voltage output, it should be nominally between 13.6V and 13.9V with the AC power connected.
8. The input fuse F1 is replaceable, otherwise there are no user replaceable fuses on the PCB.

6.0 Integral Data Interface/Port

An integral RJ45 data-port and onboard UART circuitry simplifies data integration with other systems and communication networks. This data can include the operational status of the unit including output voltage and current, battery charge rates/ voltages, battery impedance, and ambient temperature. This information can easily be transmitted to a remote service centre so that prompt intervention can be actioned and, thus, avert potential costly system shutdowns.

7.0 EN50131 Harmonised Technical Specification



Specification continued on page 10

Harmonised Technical Specification		BS EN 50131-6:2008+A1:2014
Essential Characteristics	Performance	Clause
Performance of power supply		
- General requirements	Pass	4
- Functions	Pass	5
- Materials, design and manufacture	Pass	6
Operational reliability		
- General requirements	Pass	4
- Functions	Pass	5
- Materials, design and manufacture	Pass	6
- Documentation	Pass	7
- Marking	Pass	8
Durability of operational reliability (temperature resistance)		
- Cold (operational)	Pass	9.5
Durability of operational reliability (vibration resistance)		
- Impact (operational)	Pass	9.7
- Vibration, sinusoidal (operational)	Pass	9.8
- Vibration, sinusoidal (endurance)	Pass	9.15
Durability of operational reliability (electrical stability)		
- Electrical Compatibility (EMC), - Immunity tests (operational)	Pass	9.9
Durability of operational reliability (humidity resistance)		
- Damp heat, steady state (operational)	Pass	9.6
- Damp heat, steady state (endurance)	Pass	9.14

Dycon Power Solutions Ltd

Unit A, Cwm Cynon Business Park,
Mountain Ash, CF45 4ER, United Kingdom.

For information about any Dycon product:

www.dyconpower.com

sales@dyconpower.co.uk



Manual

Data Sheet

Dycon leads the security and associated power supply markets, with UK design and manufacture of advanced power products, engineered to provide high quality, cost-effective solutions to meet current regulations and the specific needs of system integrators and end-users.

D1632 Manual 08012025v11